

A NEW METHOD OF INDUCTIVE SENSOR IMPEDANCE MEASUREMENT APPLIED TO THE IDENTIFICATION OF VEHICLE PARAMETERS

Zbigniew Marszałek, Ryszard Sroka, Marek Stencel

AGH - University of Science and Technology, Department of Measurement and Instrumentation, Al. Mickiewicza 30, 30-059 Cracow, Poland (rysielsk@agh.edu.pl, antic@agh.edu.pl, masten@agh.edu.pl, +48 12 617 39 72)

Abstract

Inductive loop sensors are widely used for detection of presence, measurement of parameters as well as classification of vehicles. Vehicle classification may be performed based on their magnetic profiles. The magnetic profile is a signal which is proportional to the resultant of an impedance change of the sensor, caused by the measured object (the changes are minor - of the order of 1%). Generator and bridge circuits are most commonly used as conditioning circuits for such sensors. As a result we can obtain one output signal proportional to total changes of sensor parameters (R and L). In this paper, a modified bridge circuit that allows independent measurement of the components (R and L) of the sensor's impedance, has been proposed. With that provided, it is possible to receive broader information on the object, which allows higher classification resolution. This paper provides the concept of a circuit, model testing results, processing algorithms used and the test results of a real circuit.

Keywords: inductive loop sensor, substitute parameters, magnetic profile, measurement of traffic parameters.

© 2011 Polish Academy of Sciences. All rights reserved

1. Introduction

Inductive loop sensors are at the moment the most commonly used sensors in measurements of road traffic. They are widely used for detection of vehicles in the measurement zone, counting them, measuring their speed, and classifying them. The output data of the sensors, concerning single vehicles is used for determination of the parameters that describe the current state of traffic in a given location or be used in traffic management systems [1, 2, 3]. The operation of the inductive sensors is based on the interaction of the alternating magnetic field produced by the sensor (powered by a sinusoidal alternating current) with metal elements of vehicles. In consequence it results in a change of the sensor parameters (resistance and inductance). The changes of both parameters are minor and in practice they amount to approximately 1% of the primary values. Two phenomena have an impact on the change of parameters. The first one is the generation of eddy currents in the metal elements of the vehicles. It creates a field directed opposite to the direction of the field created by the sensor (inductance change) and causing active losses detected as the change of its resistance and decrease of inductance [4]. The second phenomenon is the result of steel elements of a vehicle acting as a ferromagnetic core. In that case they increase the flux linked to the sensor and in consequence increase its inductance.

Until now all the phenomena in the sensor were used only as resultant change in its impedance, causing a specific result at the output of the circuit cooperating with the sensor (for example bridge methods), or only one of the effects was used (for example an inductance change) in the generator circuit. In effect a signal was received that was useful only for the detection of a vehicle, and for resulting applications, for instance a measurement of vehicle's speed with a two-sensor circuit or simple classification.

In this paper a sensitive enough circuit allowing for independent separation and measurement of both components of impedance, has been proposed. The separation of the components provides a much broader knowledge of the measured object than the circuits used earlier. The resistance component carries data about the chassis profile, and the inductance component may be used for detection and counting of vehicle's axles (which was extremely difficult in the circuits used so far). The information received that will be used for a fuller description of an object and will allow for a more selective classification. Certain works in that direction had been performed and partially presented in [5].

2. Overview of the applied methods

In the currently applied solutions a coil with few turns, placed in the road surface, is used as a sensor. It may operate within a parallel resonant circuit and in that situation, the useful information comes from the generator's frequency change resulting from the inductance change of the sensor (Fig. 1a).

Another solution is to use an AC bridge (Fig. 1b) [6]. Then the output signal is its unbalance voltage. This voltage - after amplification, filtering and demodulation is called the magnetic profile of a vehicle [7, 8]. Based on its analysis an estimation of speed, length and simple classification [9, 10] is possible.

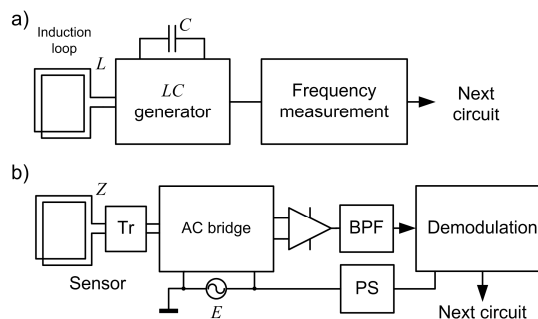

Fig. 1. The presently used solutions: a) frequency method b) bridge method, where Tr – transformer, BPF – band-pass filter, PS – phase shifter.

3. Inductive sensor in a simple meter circuit

Inductive loop sensors are typically included in actual application systems through a transformer. The purpose of this is a galvanic separation of the signal conditioning circuit from the sensor and a change in its parameters (usually an increase) linked with the transformer turns ratio.

The simplest circuit in which an inductive sensor may be used is a circuit that results from the technical method of measurement of impedance. The diagram of the circuit in concern, connection method of the sensor and a phasor have been presented in Fig. 2.

Except for the parasitic capacitances, the model of an inductive loop may be considered as R and L elements connected in series. Sinusoidal voltage is an input function (with an assumption that the internal resistance of the source equals zero), thus there will be a sinusoidal voltage on the meter resistor R_4 that will have a phase lag in relation to the supply voltage by a phase angle φ , in relation to the nominal parameters of the sensor (Fig. 2c). Changes of this voltage (its amplitude and phase) show the changes of the sensor parameters.

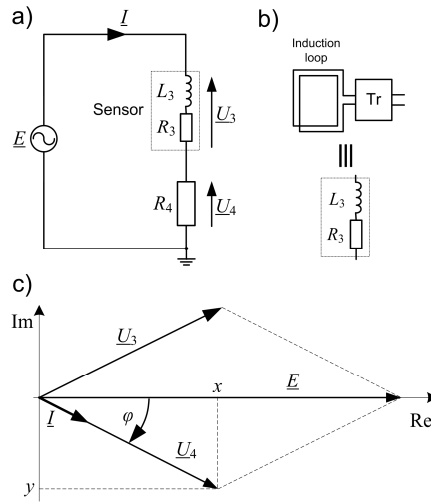

Fig. 2. An inductive sensor in a simple meter circuit: a) circuit diagram b) sensor model (Tr – transformer); c) phasor of voltages and current.

The aim is to evaluate the parameters of the sensor model concerning an influence of the measured objects. In that case, the changes of the parameters of the sensor cause changes in current in the circuit and are visible as changes of voltage in the meter resistor R_4 . Based on Fig. 2c, the real x and imaginary y component of the voltage \underline{U}_4 may be presented as:

$$x = U_4 \cos \varphi, \quad y = U_4 \sin \varphi. \quad (1)$$

With known parameters of the voltage source, in turn, the value of the sensor's impedance may be calculated from the equation:

$$\underline{Z}_3 = \frac{\underline{U}_3}{\underline{I}} = \frac{(\underline{E} - \underline{U}_4)R_4}{\underline{U}_4} = \frac{R_4 \underline{E}}{\underline{U}_4} - R_4. \quad (2)$$

Based upon Fig. 2c, the voltage \underline{U}_4 may be presented as $\underline{U}_4 = x - jy$, and thus

$$\underline{Z}_3 = \frac{R_4 \underline{E} \cdot (x + jy)}{x^2 + y^2} - R_4 = R_3 + jX_3. \quad (3)$$

Comparing the real and imaginary parts of the above equation obtains the requested component sensor impedance as:

$$R_3 = R_4 E \frac{x}{x^2 + y^2} - R_4, \quad X_3 = R_4 E \frac{|y|}{x^2 + y^2}. \quad (4), (5)$$

The starting point, then, is an appropriate choice of the resistance value R_4 and of the power supply source parameters, as well as precise measurement of the imaginary and real component of the voltage across this resistance.

A simulation of the circuit presented in Fig. 2 was performed, assuming the following nominal parameters: $R_{30} = 90 \, \Omega$, $L_{30} = 16 \, \text{mH}$, amplitude of power supply $E=10 \, \text{V}$ with a frequency $f=10 \, \text{kHz}$ and $R_4=180 \, \Omega$. The substitute parameters of the sensor have been made variable by increasing the resistance value R_3 by 1%, and change of the inductance value L_3 by $\pm 0.5\%$. The calculations have been performed with an adequately small parameter change step, to obtain an outline of the area in which there is an end of the voltage vector \underline{U}_4 on a

complex plane. The results are presented in Fig. 3. The area marked with number 1 concerns the increase in the R_3 and L_3 parameters, while the area marked with 2 concerns the decrease of L_3 parameter an increase in the R_3 parameter.

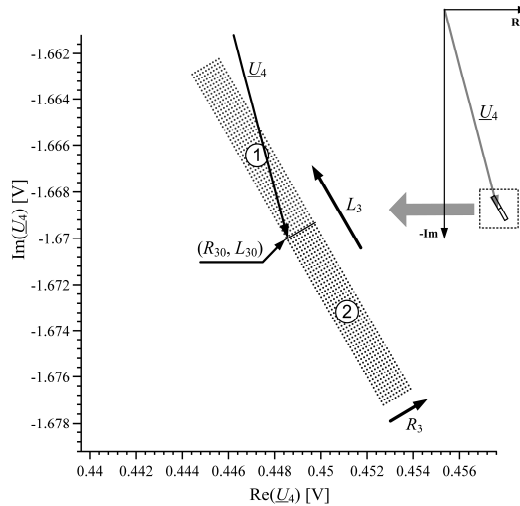

Fig. 3. The range of the \underline{U}_4 voltage for 1% changes of the substitute parameter values of the sensor.

The implication of Fig. 3 is that the changes of module and phase of \underline{U}_4 are very small in comparison to the value of this voltage for the nominal values of the sensor (fluctuations of voltage values in the meter resistor during the passage of a vehicle above the inductive loop, in a real circuit are at mV levels). This implies that a precise measurement of changes in this voltage, thus also determination of a change of the searched parameters, may be extremely difficult. Hence, a modified meter circuit is proposed.

4. The modified method and the meter circuit

The method suggested in this paper is a modification of a method that uses a Maxwell-Wien bridge. A new structure of a meter circuit with all important signals marked is presented in Fig. 4.

The basic structure of the bridge is represented by elements placed in gray areas marked as RRL and RRC and is complemented by two active phase shifters and a resistance voltage divider.

Resistors R_1 and R_2 are used for the adjustment of phase and voltage amplitude \underline{U}_c . Voltage \underline{U}_c is shifted in phase by a small fixed angle $\Delta\varphi_1$ in the first active phase shifter $PS_{(1)}$ and is connected to the voltage divider and to the input of the second active phase shifter $PS_{(2)}$. The output voltage \underline{U}_a of the $PS_{(2)}$ shifter is shifted by a very small angle $\Delta\varphi_2$. Active phase shifters do not change the amplitude of the signals [11]. At the output of the voltage divider (resistors R_5 and R_6) the \underline{U}_r voltage, that is a point of reference for balance indicator V_R , is obtained. The balance indicator is incorporated between b and r nodes. By proper setting of the resistance value R_1 and R_2 the state in which the balance indicator V_R is at the valley (low) value is reached. In this state the \underline{U}_r voltage is equal (has the same amplitude and phase) to the \underline{U}_4 voltage. The \underline{U}_c voltage leads in phase with respect to the \underline{U}_4 voltage and the \underline{U}_a voltage is delayed in phase with respect to the \underline{U}_4 voltage.

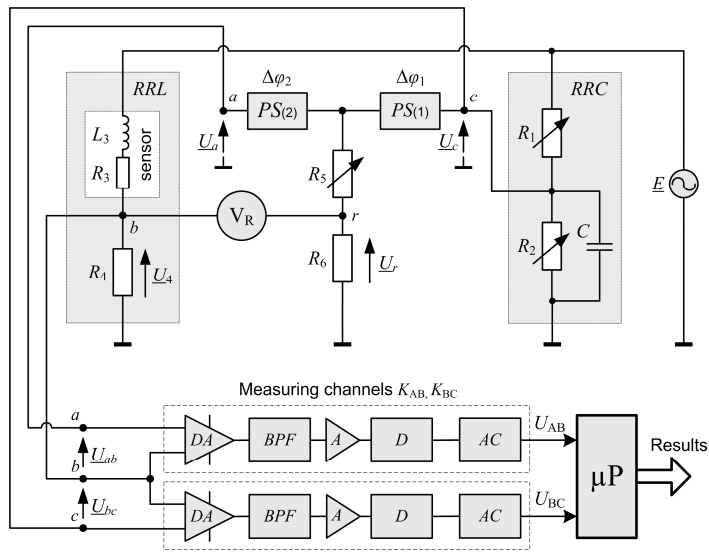

Fig. 4. A diagram of the modified meter circuit, where PS – active phase shifter, V_R - balance indicator, DA – differential amplifier, BPF – band-pass filter, A – amplifier, D – peak detector, AC – analog-to-digital converter, μP - microprocessor.

The parameters of \underline{U}_a and \underline{U}_c signals were matched so that changes in the parameters of the sensor and, consequently, in the parameters of \underline{U}_4 voltage would lead to significant changes in voltages \underline{U}_{ab} and \underline{U}_{bc} that can be subsequently processed and ensure high definition and accuracy of measurements. Timings of those signals (obtained by simulation) in nominal conditions and with the measured object are presented in Fig. 5.

In Fig. 6 vector diagrams of analyzed signals in nominal state (in state of balance) and with the measured object are presented.

By the term state of balance it is meant that the \underline{U}_r voltage is in between the vectors of voltages \underline{U}_a and \underline{U}_c . The amplitudes of differential voltages U_{ab} and U_{bc} in a state of balance have similar values (Fig. 5c and 6a). The amplitude of the voltage \underline{U}_4 is smaller than amplitudes of voltages \underline{U}_a and \underline{U}_c , because of the balancing to the \underline{U}_r voltage that was decreased by resistance dividers R_5 i R_6 . Resistor R_5 is used to set up the proper working point of the system. With the measured object (vehicle) voltage \underline{U}_4 varies as the result of changes in the substitute parameters of the sensor. Such situation is presented in Fig. 5d (in time) and in Fig. 6b (in the complex numbers plane). The coordinates of points $a(x_a, y_a)$ and $c(x_c, y_c)$ marked in Fig. 6 after preliminary balance are constant. Only alterations in the value of voltage \underline{U}_4 would cause changes in voltages U_{ab} and U_{bc} . As far as the proposed method is concerned, only changes in amplitudes of above-mentioned voltages are significant.

The phase shift imposed by phase shifters $PS_{(1)}$ and $PS_{(2)}$ and the value of the R_5 resistor are matched to “catch” the \underline{U}_4 voltage variation range (Fig. 3) which means that the \underline{U}_4 voltage variation range should be between vectors \underline{U}_a and \underline{U}_c and to the left of straight line m that contains points a and c (Fig. 6a). In such a way sufficient sensitivity to slight (1%) changes in sensor parameters is obtained.

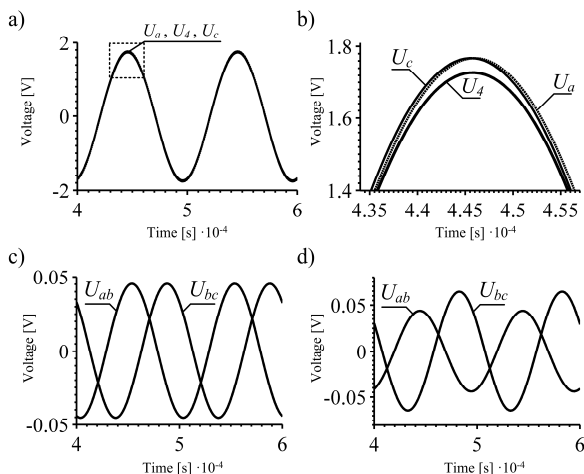

Fig. 5. Examples of signal timing: a) U_a , U_4 , U_c ; b) a magnified view of Fig. 5a; c) U_{ab} and U_{bc} voltages in balance; d) U_{ab} and U_b voltages with measured object (vehicle).

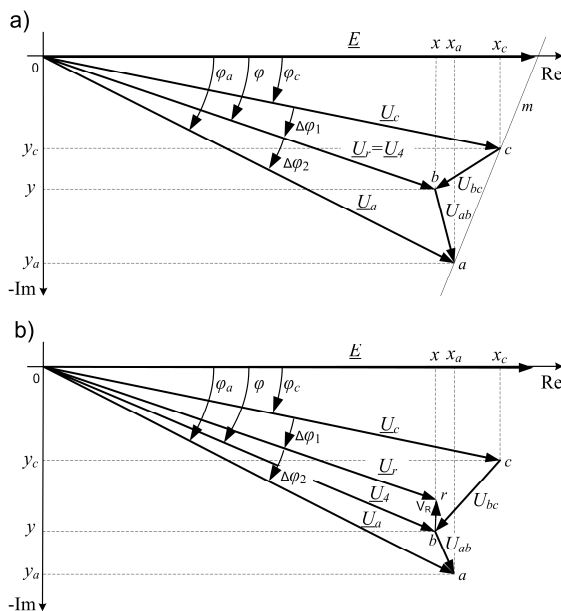

Fig. 6. Vector diagram of voltages: a) nominal state; b) with the measured object.

After proper amplification and filtering out all possible disturbances voltages U_{ab} and U_{bc} are converted into digital data that is further analyzed in the microprocessor.

5. Digital conversion and obtained results

At the beginning of the program performed by the microprocessor, constant parameters and coefficients of the meter circuit are determined, eg. coordinates of the constant points $c(x_c, y_c)$ and $a(x_a, y_a)$. The second part of the program is to implement the algorithm, which,

based on momentary values of voltages U_{AB} and U_{BC} , systematically determines the coordinates (x, y) of point b (see Fig. 6).

Based on those coefficients that are part of equations (4) and (5) and then the sought-after parameters of a sensor model, are determined.

$$k_R = \frac{x}{x^2 + y^2}, \quad k_L = \frac{|y|}{x^2 + y^2}; \quad (6), (7)$$

$$R_3 = k_R R_4 E - R_4, \quad L_3 = k_L \frac{R_4 E}{\omega}. \quad (8), (9)$$

The results are stored in the memory and can be displayed in the form of profiles, variable in time, corresponding to changes in the R and L sensor parameters.

Using the structure presented in Fig. 4, the meter circuit has been built and tested. The digital part consisted of a NI USB-6009 data acquisition card and a PC computer. During tests a small-sized inductive loop (its parameters, however, were close to the parameters of standard inductive loop sensors) and a model of a vehicle with a flat steel chassis were used. As the result of moving such vehicle over the sensor, signals presented in Fig. 7 were obtained. The magnetic profile (Fig. 7a) is a signal from the standard system cooperating with a bridge, with no modifications applied. In Fig. 7b output voltages from the signal processing line in the modified circuit are presented, while Fig. 7c and 7d shows substitute parameters of the sensor calculated by the algorithm.

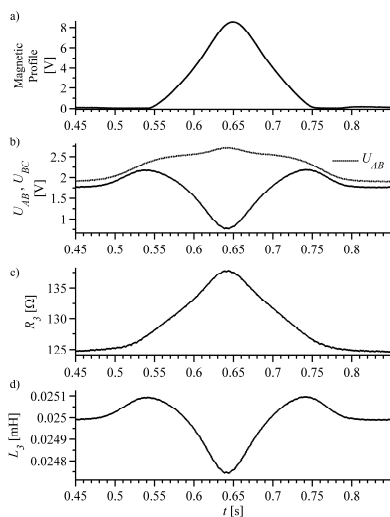

Fig. 7. Signals: a) magnetic profile from system without modifications; b) the output signals of measuring channels in modified circuit; c) R_3 profile; d) L_3 profile.

6. Summary

In this paper a proposition of a modified measurement circuit cooperating with an inductive loop sensor was presented. The aim of this circuit is to directly measure the impedance components of a sensor and its changes (profiles) when an object is affecting the sensor. Instead of recording only the changes in the impedance of the sensor (as in standard bridge circuits), two signals proportional to changes in both impedance components were

obtained. Signals obtained this way contain more information concerning an object. It was established that with this solution, a detection not only of the vehicle, but also of axles of a vehicle is possible. It enables more selective schemes of vehicle classification.

An accuracy assessment of R and L measurements was not done at this moment, because in the presented application of the new method it is not a critical parameter. More important in this application is the repeatability of output signals for the same objects and resistance of the system to the influence of external factors (e.g. weather).

Our further research is going to be aimed at building a circuit that could work in real traffic conditions and at methods of fusion of the signals obtained that way. The proposed new method will be also tested for accuracy.

Acknowledgment

This paper was financed by the Polish Ministry of Science and Higher Education, grant No: N N505 375 537

References

- [1] May, A.D. (1990). *Traffic Flow Fundamentals*. Prentice Hall, Englewood Cliffs, New Jersey 07632.
- [2] Klein, L.A. (2001). *Sensor Technologies and Data Requirements for ITS*. Artech House.
- [3] Boel, R., Mihaylova, L. (2004). Modeling Freeway Networks by Hybrid Stochastic Models. *Proceedings of IEEE Intelligent Vehicles Symposium*, Parma, 182-187.
- [4] Hepner, H., Stroppe, H. (1972). *Magnetic and inductive testing of metals*. Slask Publishing. (in Polish).
- [5] Sroka, R. (2002). Multisensing in road traffic measurements. *Multisensor Fusion*. Kluwer Academic Publisher. NATO Science Series – Mathematics, Physics and Chemistry, 70, 715-747.
- [6] Gajda, J., Stencel, M. (1997). Determination of Road Vehicle Types Using an Inductive Loop Detector. *Proceedings of XIV IMEKO Congress*. Tampere, Finland, 231-236.
- [7] Ki, Y.K., Baik, D.K. (2006). Vehicle Classification Algorithm for Loop Detectors using Neural Network. *IEEE Transactions on Vehicular Technology*, 55(6), 1704-1711.
- [8] Gajda, J., Sroka, R., Żegleń, T. (2007). Multisensor Data Fusion in the Process of Weighing and Classification of the Moving Vehicles. *Advances and Challenges in Multisensor Data and Information Processing*. IOS Press, Amsterdam, 324 – 330.
- [9] Gajda, J., Sroka, R. (2000). Vehicle Classification by Parametric Identification of the Measured Signals. *Proceedings of XVI IMEKO World Congress*. Vienna, 9, 199-204.
- [10] Burnos, P., Gajda, J., Piwowar, P., Sroka, R., Stencel, M., Żegleń, T. (2007). Measurements of Road Traffic Parameters Using Inductive Loops and Piezoelectric Sensors. *Metrology and Measurement Systems*, 14(2), 187-203.
- [11] Sidor, T. (2006). *Electrical and Electronic Measurements and Instrumentation*. AGH - Academic Press, Cracow.